

**Kombinationen nach
DIN EN 179 und 1125**

**Combinations according to
DIN EN 179 and 1125**

**B5-D
B5-E
B5-B**

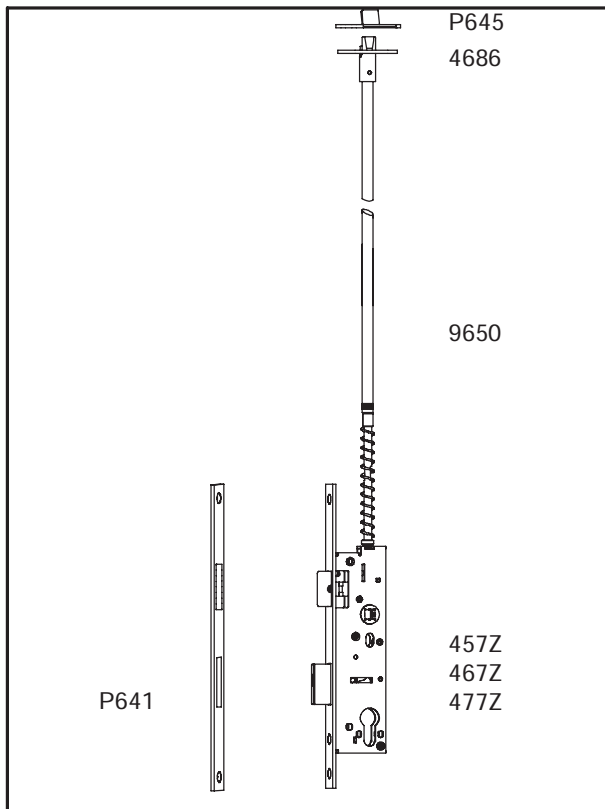

Art.Nr. Item no.	Beschreibung Description	Seite Page
457Z 467Z 477Z	Anti-Panik-Schloss für einf. Rohrrahmentüren panic lock for single metal frame doors	05-02 05-05 05-07
9650	Treibriegelstange shoot bolt	07-11
4686	Schnappschloss spring loaded latch lock	07-03
P645	Schließblech zu 4686 striking plate for 4686	06-30
P641	Schließblech striking plate	06-25

Kombinations Nr. Combination No.	Art.-Nr Art.-No.	Funktion Function	Funktionsbeschreibung Function description
B5-D-179 B5-D-1125	457Z	Durchgangsfunktion D Transit function D	Seite 05-02 Page 05-02
B5-E-179 B5-E-1125	467Z	Wechselfunktion E Transmission function E	Seite 05-05 Page 05-05
B5-B-179 B5-B-1125	477Z	Umschaltfunktion B Change-over function B	Seite 05-07 Page 05-07



Lappenschließbleche für Verriegelung nach oben

Strikingplates for top locking



Schloss-Typ Lock type	4685, 4686, 4687		Schließblech Strikingplate		Art.-Nr. Art.-No. P645	
			Maße dimen. 24x3x60mm		Zg.-Nr. drw.-No. 10 26 843	
			Varianten-Nr. ver.-No.	Mat./Oberfl. Mat./surface	käftig square ends	rund radius ends
			000001	N 1	X	DIN links DIN left
			DIN rechts DIN right			
Lappen in 0,5mm Schritten ablängbar. Maximallänge siehe Zeichnung. Schlossrichtung bitte angeben. Tongue can be shortened in 0,5mm intervalls. Maximum length see drawing. Please specify lock direction.						

Schnappschloss

Snap lock

4686

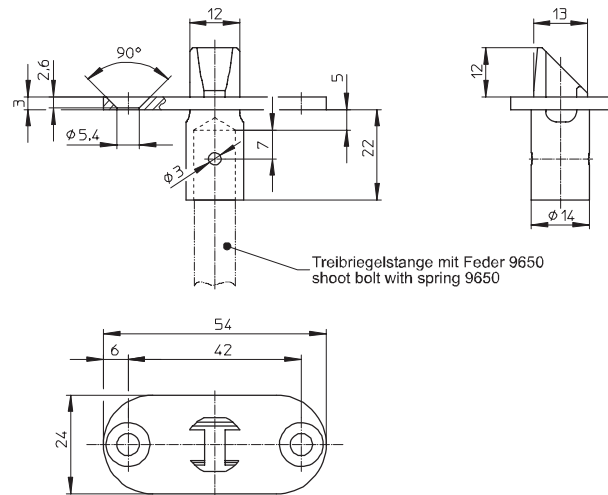

Schnappschloss für zusätzliche Verriegelung nach oben, für Schlösser mit Verriegelung nach oben in Verbindung mit der Treibriegelstange 9648/9650, Stulp 24x54mm abgerundet, Schloss ganz verzinkt, Falle Stahl.

Sonderausführungen:

- Stulp 24x50mm rund
- Stulp 24x80mm rund
- Stulp 20x54mm rund
- Stulp 20x80mm rund

Snap lock for additional top locking facility, suitable for locks with top locking facilities in conjunction with shoot bolt 9648/9650, face plate 24x54mm with rounded edges, fully galvanised lock, steel latch.

Optional designs:

- Face plate 24x50mm round
- Face plate 24x80mm round
- Face plate 20x54mm round
- Face plate 20x80mm round

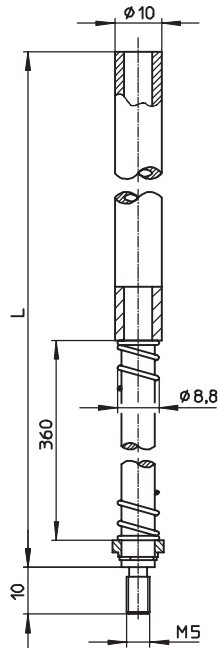
Treibriegelstange
Shoot bolt
9650

Türhöhe/door height	L
2000-2499mm	1400
2500-2999mm	1900
3000-3500mm	2400

Treibriegelstange hohl (ohne Gleitstopfen), mit zusätzlicher Feder, für Gangflügel, Anschlussgewinde M5, in Verbindung eines Schnappschlosses 4686/4687 und eines Gangflügelschlosses mit Verriegelung nach oben sowie eines gefederten Schnappschlosses 4687 mit Anti-Panik-Gegenkasten 462E.

Mit speziellen, leicht wechselbaren Distanzhüllen zur Anpassung der Federkraft an die Stangenlänge (zum Patent angemeldet).

Hinweis:

Beim Kürzen der Treibriegelstangen unbedingt Hülsenzahzahl anpassen (siehe Seite 09-12)

Hollow shoot bolt (without sliding stopper), with additional spring, for the active leaf, M5 connector thread, for top locking in conjunction with snap lock 4686/4687 and lock with additional top locking.

Equipped with easily exchanged distance sleeves to adapt the elastic force of the spring to the length of the bolt (patent applied for).

Please note:

When shoot bolts are shortened the number of sleeves must be adjust (see page 09-12)



Schließbleche für Rohrrahmentüren

Strikingplates for metal frame doors

Schließblech Strikingplate						Art.-Nr. Art.-No. P641		Schloss-Typ Lock type 457Z, 4657, 467Z, 4667, 4677, 477Z, 633N, 633Z, 634Z
Maße dimen. 24x3x245mm						Zg.-Nr. drw.-No. 10 26 722		
Varianten-Nr. ver.-No.	Mat./Oberfl. Mat./surface	käftig square ends	rund radius ends	DIN links DIN left	DIN rechts DIN right			
000001	N 1	x		x	x			
Schließblech Strikingplate						Art.-Nr. Art.-No. P642		
Maße dimen. 22x3x245mm						Zg.-Nr. drw.-No. 10 26 723		
Varianten-Nr. ver.-No.	Mat./Oberfl. Mat./surface	käftig square ends	rund radius ends	DIN links DIN left	DIN rechts DIN right			
000001	N 1	x		x	x			
Schließblech Strikingplate						Art.-Nr. Art.-No. P643		
Maße dimen. 24x6x245mm						Zg.-Nr. drw.-No. 10 26 724		
Varianten-Nr. ver.-No.	Mat./Oberfl. Mat./surface	käftig square ends	rund radius ends	DIN links DIN left	DIN rechts DIN right			
000001	N 1	x		x	x			
Schließblech Strikingplate						Art.-Nr. Art.-No. P644		
Maße dimen. 22x6x245mm						Zg.-Nr. drw.-No. 10 26 725		
Varianten-Nr. ver.-No.	Mat./Oberfl. Mat./surface	käftig square ends	rund radius ends	DIN links DIN left	DIN rechts DIN right			
000001	N 1	x		x	x			

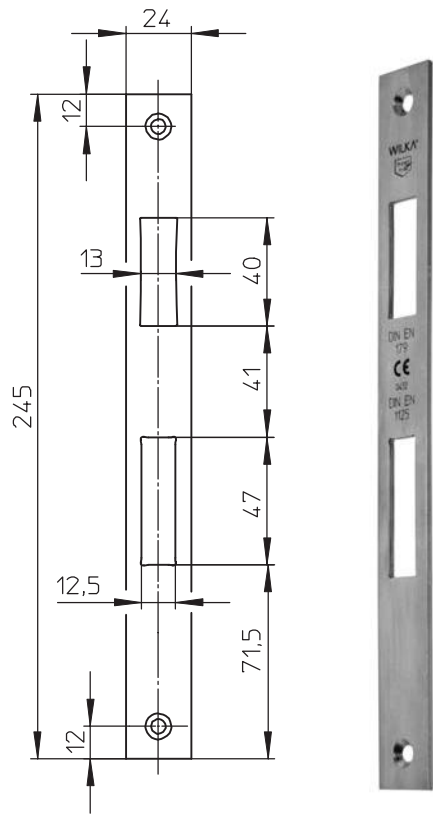

Aufgeführte Schließbleche sind optional mit Riegel-schaltkontakten lieferbar.

Specified striking plates are optionally available with dead bold control.

